

THIS DRAWING IS UNPUBLISHED. RELEASED FOR PUBLICATION 20
© COPYRIGHT 20 BY - ALL RIGHTS RESERVED.

LOC	DIST	REVISIONS					
		P	LTR	DESCRIPTION	DATE	DWN	APVD
-	-		B	REVISED (3) PER E.O. 62683	691006	-	DAB
			C	REVISED PER E.O. A12333	920131	-	JP
			D	REVISED PER ECR-13-016042	131028	G.S.	RC
			E	REVISED PER ECO-14-000052	140102	MD	JF

PROPERTY OF TE CONNECTIVITY
THIS INFORMATION IS CONFIDENTIAL AND PROPRIETARY TO TYCO ELECTRONICS CORPORATION AND ITS WORLDWIDE SUBSIDIARIES AND AFFILIATES (TE). IT MAY NOT BE DISCLOSED TO ANYONE, OTHER THAN TE PERSONNEL, WITHOUT AUTHORIZATION FROM TE (www.TE.com).

PART NUMBER	SIZE	WIRE RANGE	SEALING RANGE		A ±.010	B ±.010	C MIN	INSERT AND EXTRACT TOOL NUMBER	CRIMP TOOL
			MIN. O.D.	MAX. O.D.					
100060-56	22	26-24-22	.033	.054	.058	.321	.146	M15570-22-1	MH800 WITH POSITIONER K127
1841-1-5616	16	20-18-16	.068	.103	.132	.378	.250	M15570-16	M22520/1-01
1841-1-5612	12	14-12	.106	.158	.188	.418	.250	M15570-12	M22520/1-01
1841-5-5608	8	8	.127	.203	.252	.465	.300	M15515-103	20399

E
D1
D2

SIZE	APPROX. WT. PER CONTACT IN LBS.
22	.0002
16	.0008
12	.0018
8	.0031

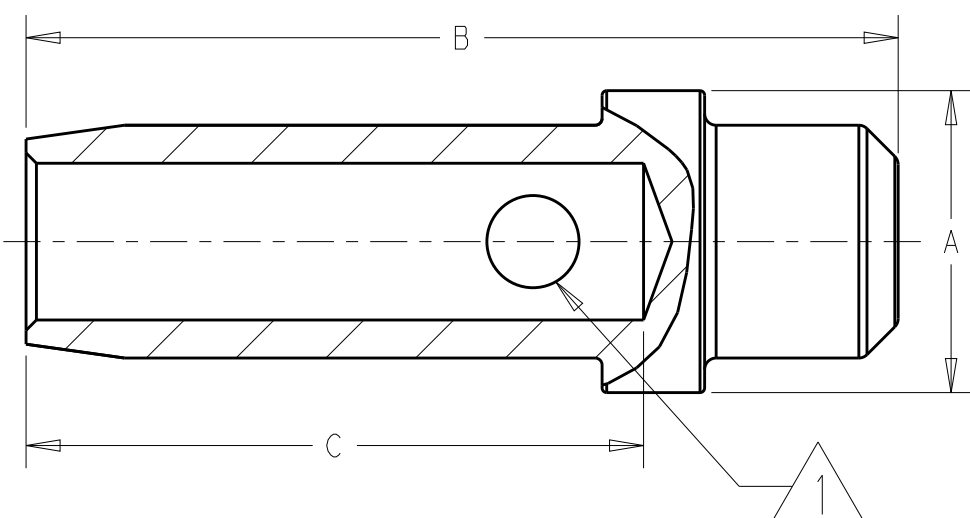

SIZE: 16, 12, 8

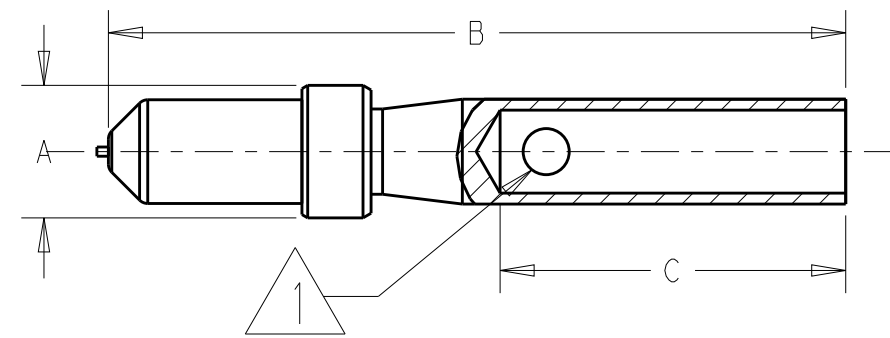

SIZE: 22 ONLY

- NOTES:
- 4. FINISH - GOLD PLATE PER MIL-G-45204 TYPE II, CLASS 1.
 - 3. CONTACT MATERIAL - COPPER ALLOY
 - 2. SEE "GENERAL DESCRIPTION" FOR ELECTRICAL AND MATERIAL SPECIFICATION
 - 1. WIRE INSPECTION HOLE (ONE WALL ONLY)

THIS DRAWING IS A CONTROLLED DOCUMENT.		DWN J.P.	681025	STE TE Connectivity	
DIMENSIONS: INCHES		CHK B.L.	681122		
TOLERANCES UNLESS OTHERWISE SPECIFIED:		APVD AR	131028	NAME CONTACTS, TERMINAL JUNCTION SIZE: 22, 16, 12, AND 8 ENVELOPE	
0 PLC ±. 1 PLC ±0.1 2 PLC ±0.01 3 PLC ±0.002 4 PLC ±0.0005 ANGLES ±		PRODUCT SPEC -		SIZE A3	
MATERIAL 3.		APPLICATION SPEC -		CAGE CODE -	
FINISH 4.		WEIGHT -		DRAWING NO G-61800_DEUTSCH	
		Customer Drawing		RESTRICTED TO -	
		SCALE 9:1		SHEET 1 OF 1 REV E	